

METAL KÖRÜKLÜ VANA

METAL BELLOWS SEALED GLOBE VALVE

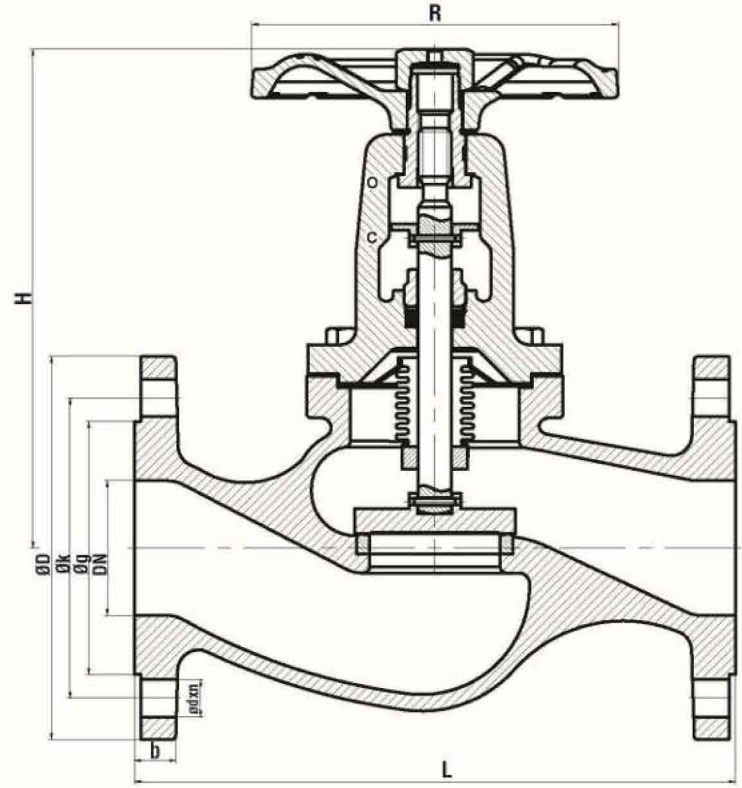
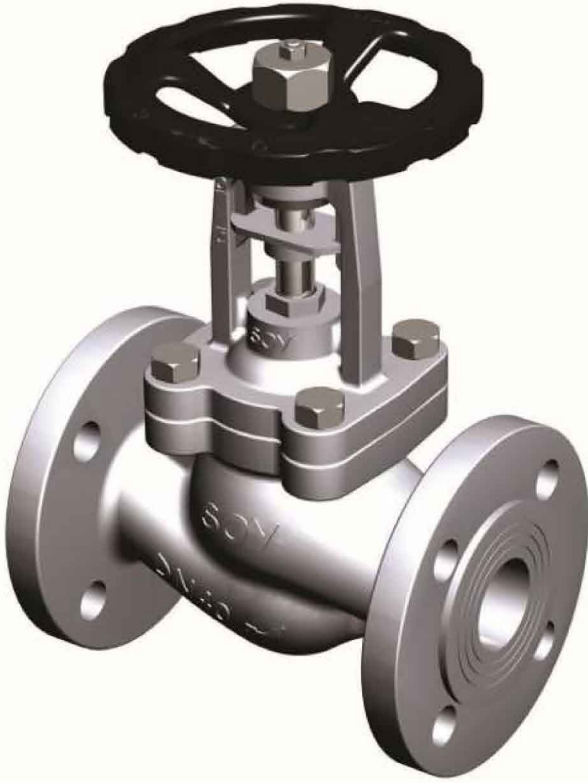

NO	PARÇA ADI	PART NAME	MALZEME / MATERIAL		NO	PARÇA ADI	PART NAME	MALZEME / MATERIAL	
			PN16	PN25				PN16	PN25
1	GÖVDE	BODY	GG25	GGG40.3	12	İNDİKATÖR	INDICATOR	ST	ST
2	SİT	SEAT	AISI 420	AISI 420	13	PİM	PIN	AISI 304	AISI 304
3	KAPAK	BONNET	GGG40.3	GGG40.3	14	SALMASTRA BASKISI	PACKING JOINT	AISI 420	AISI 420
4	MİL	STEM	AISI 420	AISI 420	15	KLAPE	DISC	AISI 420	AISI 420
5	KÖRÜK	BELLOWS	AISI 316Ti	AISI 316Ti	16	SARMA PİM	SPRING PIN	AISI 304	AISI 304
6	CONTA	GASKET	GRAPHITE	GRAPHITE	17	HENDİL	HANDWHEEL	GG25	GG25
7	SALMASTRA	PACKING	GRAPHITE	GRAPHITE	18	HENDİL SOMUNU	HANDWHEEL NUT	ST	ST
8	PUL	WASHER	ST37	ST37	19	ÇİVATA	BOLT	8.8 STEEL GALV.	8.8 STEEL GALV.
9	PUL	WASHER	SPRING ST.	SPRING ST.	20	SETSKUR	GRUP SCREW	8.8 STEEL	8.8 STEEL
10	KAPAK BURCU	BONNET BUSH	AISI 420	AISI 420	21	GRESÖRLÜK	LUBRICATING NIPPLE	ST	ST
11	SEGMAN	RETAINING RING	SPRING ST.	SPRING ST.					

DN	L	ØR	H	STROK	PN16					PN25					PN40					KG			
					ØD	Øk	Øg	b	n	Ød	ØD	Øk	Øg	b	n	Ød	ØD	Øk	Øg		b	n	Ød
15	130	125	190	6	95	65	45	14	4	14	95	65	45	16	4	14	95	65	45	16	4	14	4,6
20	150	125	190	6	105	75	58	16	4	14	105	75	58	18	4	14	105	75	58	18	4	14	5,35
25	160	125	195	8	115	85	68	16	4	14	115	85	68	18	4	14	115	85	68	18	4	14	6,25
32	180	125	195	8	140	100	78	18	4	18	140	100	78	18	4	18	140	100	78	18	4	18	7,2
40	200	150	220	13	150	110	88	18	4	18	150	110	88	18	4	18	150	110	88	18	4	18	11,2
50	230	150	225	13	165	125	102	20	4	18	165	125	102	20	4	18	165	125	102	20	4	18	15
65	290	175	240	16	185	145	122	20	4	18	185	145	122	22	8	18	185	145	122	22	8	18	20,6
80	310	175	260	20	200	160	138	22	8	18	200	160	138	24	8	18	200	160	138	24	8	18	23,6
100	350	225	315	25	220	180	158	24	8	18	235	190	162	24	8	22	235	190	162	24	8	22	36,5
125	400	225	420	32	250	210	188	26	8	18	270	220	188	26	8	28	270	220	188	26	8	25	55
150	480	300	500	40	285	240	212	26	8	22	300	250	218	28	8	28	300	250	218	28	8	25	77,5
200	600	400	550	50	340	295	268	30	12	22	360	310	278	34	12	28	375	320	285	34	12	30	140

UYGULAMA ALANLARI / USE OPERATING

BUHAR, SICAK SU, TERMAL AKIŞKAN, KIZGIN YAĞ

STEAM, HOT WATER, THERMAL FLUIDS, HOT OIL

ÇALIŞMA ŞARTLARI / WORKING CONDITIONS : DIN 2401

BAĞLANTILAR / ENDS: DIN EN 1092-2

ÇALIŞMA BASINCI / WORKING PRESSURE : PN16

ÇALIŞMA SICAKLIĞI / WORKING TEMPERATURE

PN16: -10 +300°C,

PN25: -10 +350°C,

PN40: -10 +400°C

GÖVDE SEÇENEKLERİ

GG25, GGG40.3, GSC-25



USKON AKIŞKAN KONTROL SİSTEMLERİ SANAYİ VE TİCARET LTD. ŞTİ.

Kemankeş Kara MustafaPaşa Mah. Ağaç Tulumba Sok. No: 4/A Karaköy / İstanbul Tel: +90 (212) 251 05 05 Fax: +90 (212) 251 05 79 info@us-kon.com.tr