

### TECHNICAL SPECIFICATIONS, DESCRIPTIONS and GENERAL FEATURES

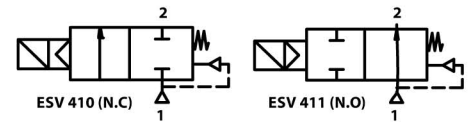

- **Fluids:** Valves are suitable for fuel oils, over heated water, hydraulic oil, low viscosity oils, etc... non-aggressive liquids but is not suitable for hazardous fluids
- **Switching Function:** Normally Closed (N.C, Closed when de-energised) (ESV 410 Series) and Normally Open (N.O, Open when de-energised) (ESV 411 Series)
- **Principle of Operation:** Pilot Operated
- **Way Number:** 2/2 (Ports / Positions)
- **Connection and Port Sizes:** G1/8" up to G1"
- **Connection Type:** Thread (Female), G (BSPP / ISO 228-1)
- **Pressure Range:** 0 -16 Bar (ESV 410 Series) , 0-12 Bar (ESV 411 Series)
- **Fluid Temperature:** -10°C to max. 160°C
- **Ambient Temperature:** -20°C to max. 70°C
- **Opening Time:** 200ms up to 1500ms
- **Closing Time:** 500ms up to 2000ms
- **Max Viscosity:** 38 cSt or mm<sup>2</sup>/s
- **Maximum Allowable Pressure or Design Pressure:** 24 bar (ESV 410 Series), 18 Bar (ESV 411 Series)
- Don't require differential pressure, internal exhaust system (for ESV 411 Series)
- Valve has sealing o-rings
- Suitable AC and DC voltage, high voltage tolerance
- Coil interchangeable without dismantling the valve (don't matter AC or DC)
- High flow rate, high reliability, high mechanical strength
- Various flow rate options, wide range of orifice options
- Mounting position, optional any position but preferably solenoid coil vertical on top
- The fluid passing through the valve must be filtered
- Flow rate (Q) can be usually calculated as a function of pressure, density and flow coefficient
- According 97/23/EC Pressure Equipment Directive (PED), 2006/95/EEC Low Voltage Directive (LVD) and 2004/108/EC Electromagnetic Compatibility Directive (EMC)

|                   |                                     |                     |                  |
|-------------------|-------------------------------------|---------------------|------------------|
| Low Pressure Loss | Don't Require Differential Pressure | Coil Rotatable 360° | High Reliability |
| Full Orifice      | Patented Enclosing Tube Design      | High Performance    | Long Life        |



| Model No       | Position | Connection and Port Size | Orifice Size | Flow Factor / Coefficient Kv |                   | Operating Pressure Differential |               |               |               | Fluid Temperature |      | Seal  | Approximate Weight | Reference Figure |
|----------------|----------|--------------------------|--------------|------------------------------|-------------------|---------------------------------|---------------|---------------|---------------|-------------------|------|-------|--------------------|------------------|
|                |          |                          |              |                              |                   | Min. (For AC)                   | Min. (For DC) | Max. (For AC) | Max. (For DC) | Min.              | Max. |       |                    |                  |
| ESV            |          | G                        | mm           | L /m                         | m <sup>3</sup> /h | Bar                             | Bar           | Bar           | Bar           | °C                | °C   |       | kg                 |                  |
| ESV 410.02     | N.C      | 3/8"                     | 12           | 40                           | 2.40              | 0,15                            | 0,15          | 10            | 10            | -10               | 160  | VITON | 0.68               | Fig.1            |
| ESV 410.03     | N.C      | 1/2"                     | 15           | 70                           | 4.20              | 0,15                            | 0,15          | 10            | 10            | -10               | 160  | VITON | 0.66               | Fig.1            |
| ESV 410.04     | N.C      | 3/4"                     | 20           | 130                          | 7.80              | 0,15                            | 0,15          | 10            | 10            | -10               | 160  | VITON | 0.86               | Fig.1            |
| ESV 410.05     | N.C      | 1"                       | 25           | 180                          | 10.80             | 0,15                            | 0,15          | 10            | 10            | -10               | 160  | VITON | 1.15               | Fig.1            |
| ESV 411.02     | N.O      | 3/8"                     | 12           | 40                           | 2.40              | 0,15                            | 0,15          | 6             | 6             | -10               | 160  | VITON | 0.71               | Fig.1            |
| ESV 411.03     | N.O      | 1/2"                     | 15           | 70                           | 4.20              | 0,15                            | 0,15          | 6             | 6             | -10               | 160  | VITON | 0.69               | Fig.1            |
| ESV 411.04     | N.O      | 3/4"                     | 20           | 130                          | 7.80              | 0,15                            | 0,15          | 6             | 6             | -10               | 160  | VITON | 0.89               | Fig.1            |
| ESV 411.05     | N.O      | 1"                       | 25           | 180                          | 10.80             | 0,15                            | 0,15          | 6             | 6             | -10               | 160  | VITON | 1.18               | Fig.1            |
| ESV 410.00.120 | N.C      | 1/8"                     | 12           | 20                           | 1.20              | 0,15                            | 0,15          | 10            | 10            | -10               | 160  | VITON | 0.73               | Fig.1            |
| ESV 410.01.120 | N.C      | 1/4"                     | 12           | 25                           | 1.50              | 0,15                            | 0,15          | 10            | 10            | -10               | 160  | VITON | 0.71               | Fig.1            |
| ESV 411.00.120 | N.O      | 1/8"                     | 12           | 20                           | 1.20              | 0,15                            | 0,15          | 6             | 6             | -10               | 160  | VITON | 0.76               | Fig.1            |
| ESV 411.01.120 | N.O      | 1/4"                     | 12           | 25                           | 1.50              | 0,15                            | 0,15          | 6             | 6             | -10               | 160  | VITON | 0.74               | Fig.1            |

### OPTIONS

- Custom options can be performed for customer's special requests
- On request; NPT (ANSI 1.20.3), R (BSPT / ISO 7-1), W (BSW / Whitworth), M (Metric) etc...
- On request; various body surface coating, nickel plated body, different body materials, internal parts stainless steel (for ESV 411), manual override, seat can be stainless steel, filter, other pipe connections, flanged connection
- On request; other special supply voltages, frequencies (60 Hz), other power, coil insulation class : F (155°C), coil duty latching model
- On request; with electronic timer , Explosion-Proof coil for use in zones 1/21-2/22 (Eex em II T4/T5), coil encapsulation material can be fiber glass reinforced (V0 or V1)
- On request; connector with LED or without connector, connector with visual indication and peak voltage suppression, connector with cable length of 2m, Spade plug (Cable Ø 8-10 mm), connector non-flammable
- On request other versions

### POWER CONSUMPTION

| Power Consumption        |         |             |              |                     |         |          |         |
|--------------------------|---------|-------------|--------------|---------------------|---------|----------|---------|
| Alternating Current (AC) |         |             |              | Direct Current (DC) |         |          |         |
| Model No                 | Voltage | Inrush (VA) | Holding (VA) | Model No            | Voltage | Cold (W) | Hot (W) |
| ECO 10.AC.012            | 12V     | 30          | 18           | ECO 10.DC.012       | 12V     | 16       | 12      |
| ECO 10.AC.024            | 24V     | 30          | 18           | ECO 10.DC.024       | 24V     | 16       | 12      |
| ECO 10.AC.048            | 48V     | 30          | 18           | ECO 10.DC.048       | 48V     | 16       | 12      |
| ECO 10.AC.110            | 110V    | 30          | 18           | ECO 10.DC.110       | 110V    | 16       | 12      |
| ECO 10.AC.230            | 230V    | 30          | 18           | ECO 10.DC.230       | 230V    | 16       | 12      |

### DIMENSIONS (mm)

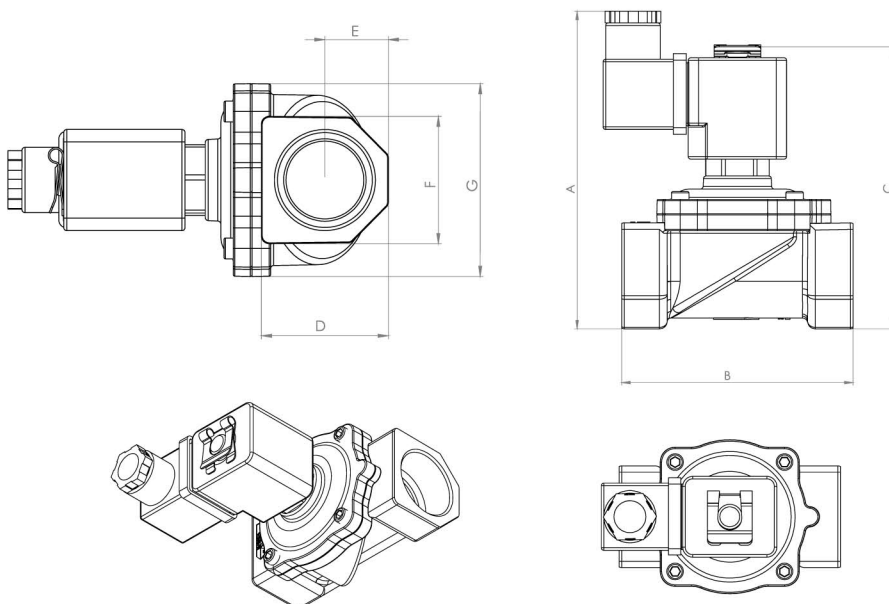

| Size | A     | B  | C     | D    | E    | F    | G    |
|------|-------|----|-------|------|------|------|------|
| 1/8" | 105.4 | 69 | 86.2  | 26.8 | 13.4 | 26.9 | 44   |
| 1/4" | 105.4 | 69 | 86.2  | 26.8 | 13.4 | 26.9 | 44   |
| 3/8" | 105.4 | 69 | 86.2  | 26.8 | 13.4 | 26.9 | 44   |
| 1/2" | 105.4 | 69 | 86.2  | 26.8 | 13.4 | 26.9 | 44   |
| 3/4" | 111.7 | 81 | 98.5  | 31.8 | 15.3 | 31.9 | 53.8 |
| 1"   | 122.3 | 89 | 108.6 | 40.8 | 20.4 | 41   | 62   |

### ELECTRICAL CHARACTERISTICS

- **Protection Degree:** IP 65 (EN 60529) ( with connector )
- **Plug Connection:** DIN 46340-3 poles connectors (DIN 43650)
- **Connector Specification:** ISO 4400 / EN 175301-803 , Form A, Spade plug (Cable Ø 6-8 mm)
- **Electrical Safety:** IEC 335, EN 60335-1, EN 60204-1
- **Coil Insulation Class:** H (180°C)
- **Coil Impregnation:** Polyester Fiber-Resin Glass
- **Coil Encapsulation Material:** Fiber Glass Reinforced (V2)
- **Supply Voltages:** For AC(−) 12V , 24V , 48V , 110V , 230V  
For DC (=) 12V , 24V , 48V , 110 V , 230 V
- **Voltage Tolerances:** For AC (−) or DC (=) %−10 ; %+10
- **Frequency:** 50 Hz
- **Coil Duty Cycle:** %100 ED, Continuously Rated
- Design according to DIN VDE 0580

### MATERIALS

- **Body:** Brass
- **Plunger Seal:** VITON
- **Enclosing Tube:** Stainless Steel (AISI 430FR and AISI 304) for ESV 410 Series , Stainless Steel (AISI 430FR and AISI 304) and Brass for ESV 411 Series
- **Plunger:** Stainless Steel (AISI 430FR)
- **Springs:** Stainless Steel (AISI 302)
- **Shading Ring:** Copper
- **Seat:** Brass
- **O-rings:** NBR
- **Internal Metal Parts:** Stainless Steel and Brass
- **Cover:** Brass
- **Diaphragm/Seat Seal:** VITON
- **Cover Screws:** Stainless Steel