

VLS5000

TUNING FORK VIBRATING LEVEL SWITCH

VLS5000

Housing: IP65

Explosion Proof:

Class I, Groups A, B, C, D;

Class II, Groups E, F, G; NEMA4X

VLS5000 Series are assembled with a tuning fork and energized sensor. It vibrates frequently with mechanical resonance to detect the liquid level when the tuning fork is immersed into process liquid.

Technical Data

Wetted part material: 316 stainless steel

Thread connection: 1" NPT, 1" BSP

Flange connection: from 1" to 3", JIS, ANSI, DIN, and Clamp available

Detection length: minimum 130 mm maximum 400 mm

Working temperature: -30°C~+80°C

Working pressure: maximum 100 kg/cm², up to 400 kg/cm² on request

Liquid viscosity: 0.2~10000 mpas

Liquid density: 0.6 g/cm³~2.5 g/cm³

Housing: IP65

Explosion Proof: Class I, Groups A, B, C, D; Class II, Groups E, F, G; NEMA4X

Power Supply: 110VAC, 220VAC, 24VDC

Contact Form: SPDT

Contact Rating: 20A/125VAC, 12A/250VAC



Housing Dimensions

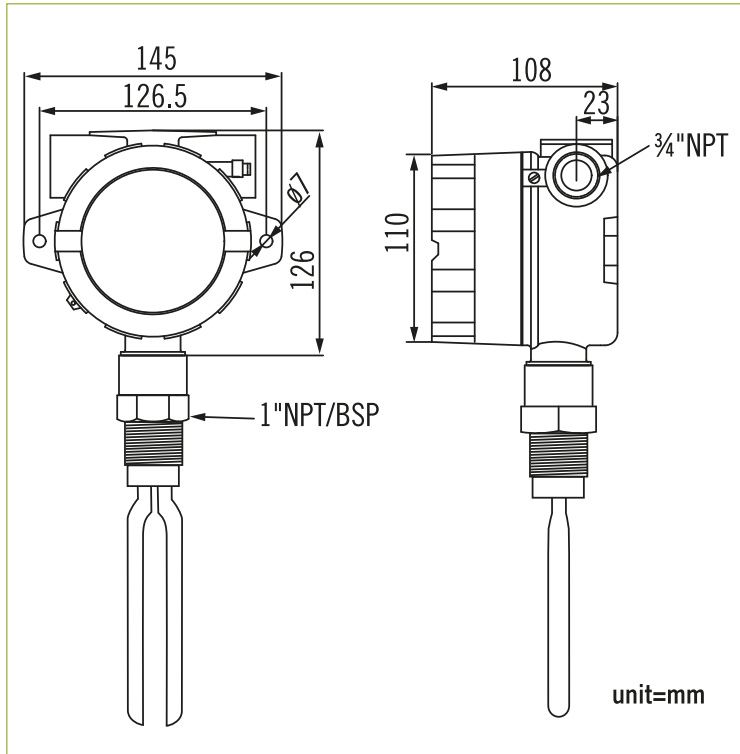

Application and Installation

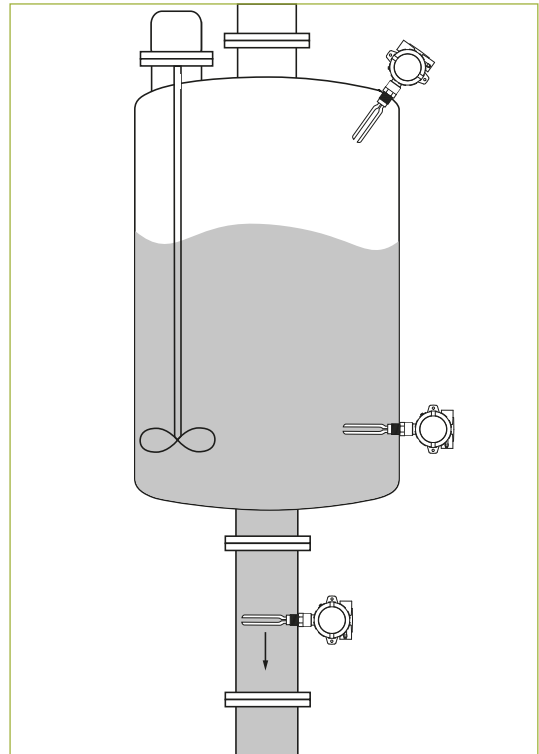

Process Connections

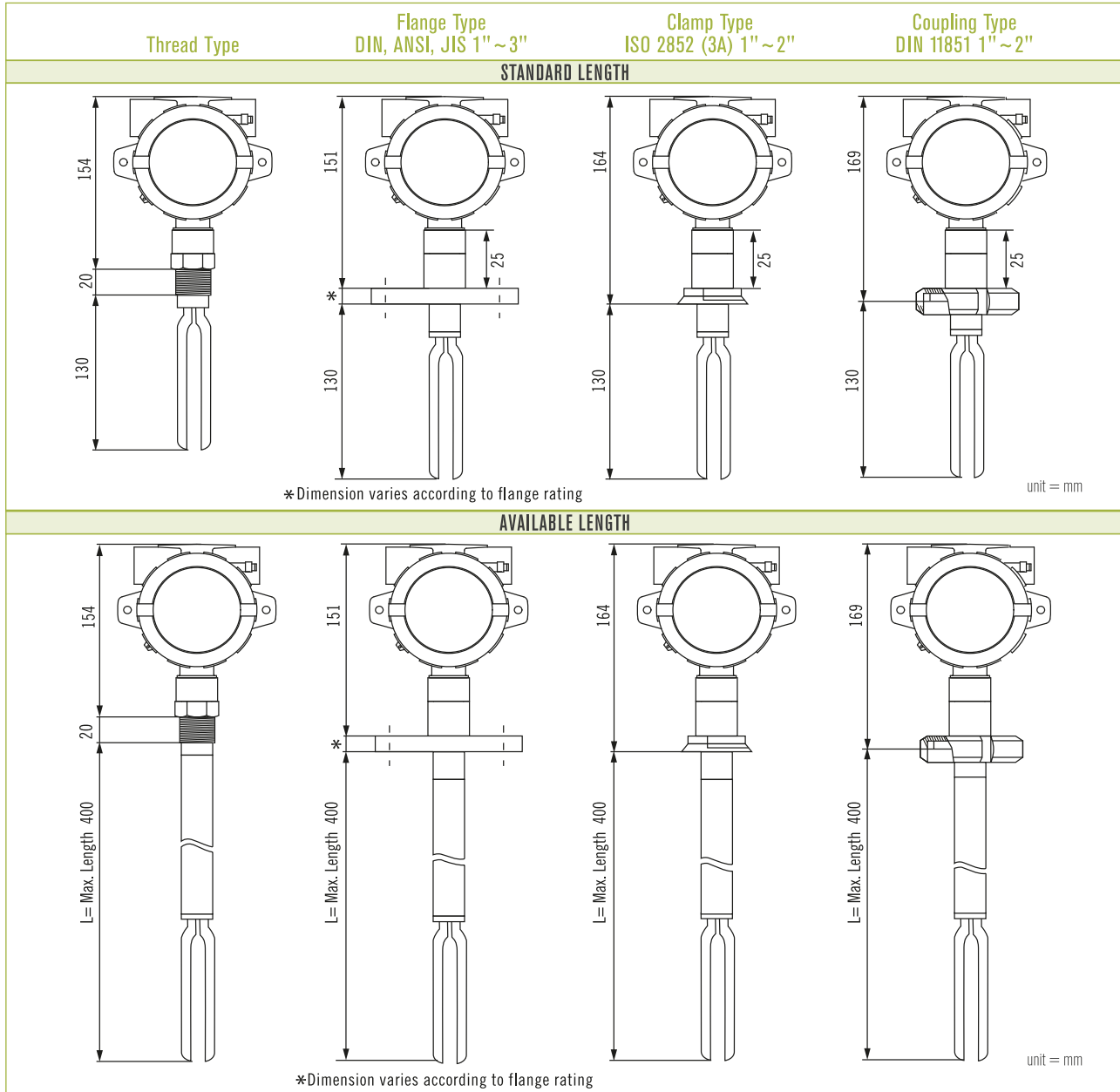

unit = mm

unit = mm

Ordering Information

VLS5000	Code	Process Connection
		(1) Thread type (2) Flange type (3) Clamp type (4) Coupling type
		Code Connection Size
		(A) 1" (B) 1½" (C) 2" (D) 3"
		Code Connection Rating
		Thread: (1) NPT (2) BSP Flange: (3) JIS10K (4) JIS20K (5) ANSI 150# (6) ANSI 300# (7) PN10 (8) PN16 (9) PN25 (0) Option: fill in the requested rating _____
		Code Electronic Connection
		(E) ¾"NPT Female, Standard (F) ½"NPT Female
		Code Insertion Length
		S Standard
		L Fill in the requested length ie: L=300mm
		Code Power Supply
		(A) 110VAC (B) 220VAC (C) 24VDC
VLS5000		Complete Ordering Code

