

VLS5500

TUNING FORK VIBRATING LEVEL SWITCH

VLS5500

Housing: IP65

Explosion Proof:

Class I, Groups A, B, C, D;

Class II, Groups E, F, G; NEMA4X

VLS5500 Series are assembled with a tuning fork and energized sensor. It vibrates frequently with mechanical resonance to detect level of powders or granular bulk solids.

Technical Data

Using in powder or solids

Wetted part material: 316 stainless steel

Thread connection: 2" NPT, 2" BSP

Flange connection: from 2" to 3", JIS, ANSI, DIN available

Detection length:

	Minimum	Maximum
Thread	200mm	450mm
Flange	245mm	450mm

Working temperature: -30°C~+80°C

Working pressure: maximum 100 kg/cm², up to 400 kg/cm² on request

Liquid viscosity: 0.2~10000 mpas

Liquid density: 0.6 g/cm³~2.5 g/cm³

Housing: IP65

Explosion Proof: Class I, Groups A, B, C, D; Class II, Groups E, F, G; NEMA4X

Power Supply: 110VAC, 220VAC, 24VDC

Contact Form: SPDT

Contact Rating: 20A/125VAC, 12A/250VAC



Housing Dimensions

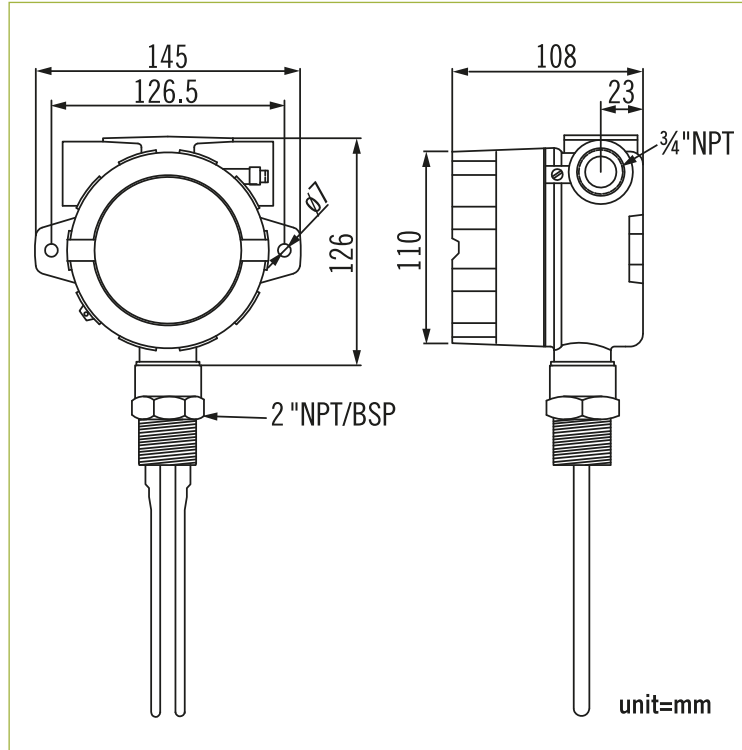

Application and Installation

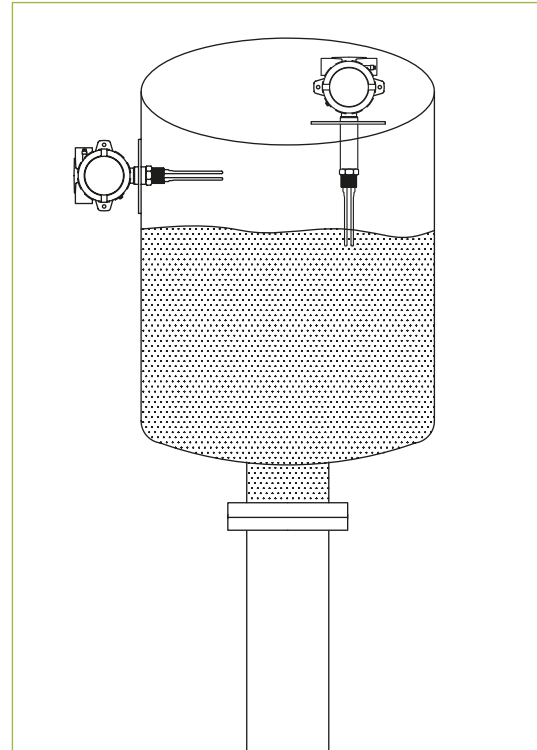

Process Connections

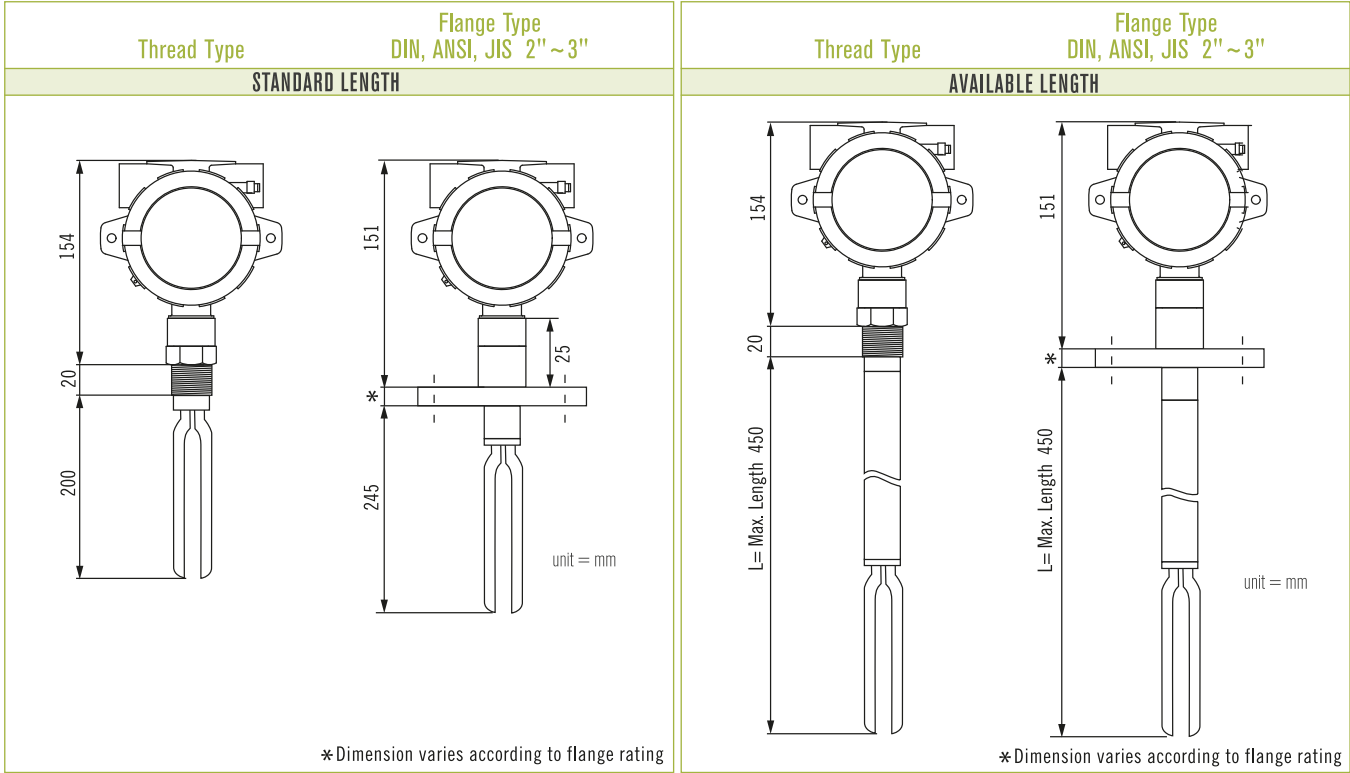

Ordering Information

VLS5500	Code	Process Connection
		(1) Thread type (2) Flange type
		Code Connection Size
		(A) 2" (B) 3"
		Code Connection Rating
		Thread: (1) NPT (2) BSP Flange: (3) JIS10K (4) JIS20K (5) ANSI 150# (6) ANSI 300# (7) PN10 (8) PN16 (9) PN25 (0) Option: fill in the requested rating _____
		Code Electronic Connection
		(E) 3/4"NPT Female, Standard (F) 1/2"NPT Female
		Code Insertion Length
		S Standard
		L Fill in the requested length ie: L=300mm
		Code Power Supply
		(A) 110VAC (B) 220VAC (C) 24VDC
VLS5500		Complete Ordering Code