

Safety valves

Instruction Manual: According to P.E.D.97/23 CE

1.1. PRELIMINARY ADVICE:

1.1.1. General instructions

Safety valves are high-responsibility accessories, which are manufactured with extreme precision. Incorrect handling can affect the hermetic properties of the seal.

1.1.2. Cleaning

Ensure that the valve is free from foreign bodies. Clean the tubes and connections thoroughly before assembly.

1.1.3. Paint

Keep all moving parts, connections and/or discharge areas free of paint.

1.1.4. Transportation

Remove protective covers and anchoring clamps from the lever when assembling.

1.1.5. Storage conditions

Temperature should be between 5 and 25°C, and relative humidity less than 75%. After 6 months, check these values before installing.

1.2. INSTALLATION:

Installation must be carried out by a qualified technician.

1.2.1. General advice

Install as close as possible to the system to be protected.

The vertical connection tube must be straight and short, and the flow section must have at least the same diameter as the valve inlet.

Avoid transmitting inadmissible static, dynamic or thermal forces from the inlets and outlets to the valve. Avoid tension.

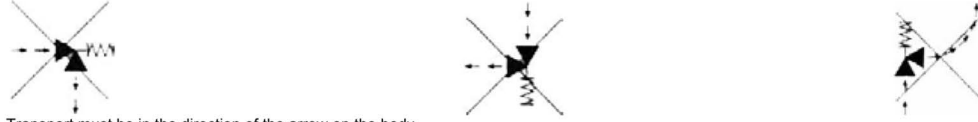

Transport must be in the direction of the arrow on the body.

Do not install any sealing devices prior to the valve.

In the case of steam, install a detour before the valve inlet in order to remove the air from the installation when it is turned on.

If the fluid is harmful, inflammable, toxic, etc., install discharge tubes that lead to a secure place.

1.2.2. Removal of condensed matter

Steam and gases

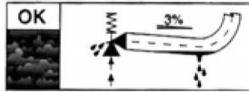

Liquids

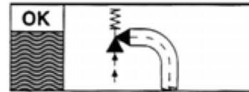

1.2.3. Insulation

The valve is left uncovered, so that the spring does not heat up.

1.2.4. Ducts

1.2.4.1. Inlet ducts: These should be as short as possible, with pressure drops of less than 3% of release pressure.

1.2.4.2. Outlet ducts: The tube must not rest on the valve. It must be self-draining and the reaction force to discharge should be taken into consideration.

The tube should be as short as possible, with sufficient diameter to limit a pressure drop through said tube to a maximum level of 10% of the release pressure.

The diameter must never be less than the diameter of the valve.

Discharge tubes should be of a sufficient size to ensure that inherent or generated counter-pressure is no greater than 15% of the release pressure.

A silencer should be installed where discharge is noisy.

1.2.6. Examples of assembly combinations

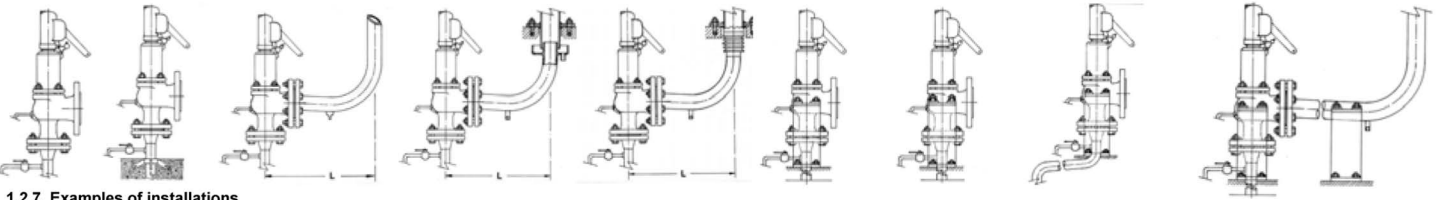

1.2.7. Examples of installations

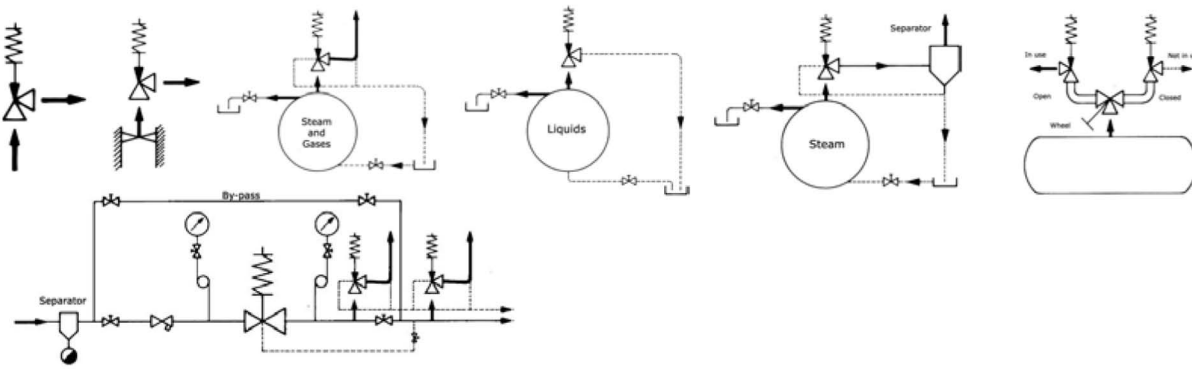

1.3. INITIATION, CHARACTERISATION AND CHECKING:

1.3.1. Initiation

To prevent unnecessary releases, we recommend that working pressure be at least 5% lower than the pressure at which the valve closes.

When initiating, prompt a manual discharge of 75 + 80% of release pressure. This will result in the tubes and the valve itself being swept out. Repeat the operation at regular intervals.

1.3.2. Characterisation

Every safety valve is assembled and checked in our workshop. They are methodically adjusted in line with release pressure, sealed and then certified before being despatched, all in accordance with the conditions set out in our ISO-9001 quality control manual.

Release pressure p , the fluid (L = liquid, S = steam, G = gas), discharge coefficient α_d , and the minimum interior diameter of nozzle d_0 are marked directly on the body or characteristics plate.

The VYC OF internal identification number and the CE stamp with the register of the certifying entity are also visible on the plate or marked on the body.

Other specifications, such as the DIN material standard, PN, flow direction arrow, VYC brand, DN, batch numbers and control numbers are stamped either in direct or inverse relief, while other necessary information is marked mechanically on the clamp or the body of the valve.

Each and every one of the components that go into our valves is marked with the DIN material regulation and the batch number, by way of internal register. Also present is the notch that identifies quality control. All of these marks are unequivocal proof of the authenticity of the components.

Should the valves be checked by accredited bodies, the latter shall make their own distinctive mark and place their identification number on the body or pressure box.

1.3.3. Checking

Check that the valve is working correctly, and that release pressure, total discharge and sealing pressure are as they should be.

Checking frequency will depend on the following: characteristics of the fluid, corrosion, residues, viscosity, etc., as well as on discharge frequency, and on environmental conditions, climate, pollution, etc.

We suggest that you carry out a preventive maintenance programme in accordance with current legislation.

1.4. DISMOUNTING, ASSEMBLING AND ADJUSTING THE RELEASE PRESSURE:

See the catalogue for the model in question or request instruction sheets.

1.5. REPAIRS:

Disassemble the valve from the installation when pressure and temperature conditions are suitable. Take no unnecessary risks!

If using hones, rectifiers, test benches, etc., we recommend that you adjust or delay the release pressure, that maintenance or repairs be carried out in our workshops with guaranteed original spare parts, or failing that, on-site by one of our mobile maintenance teams or by an authorised technician.

Clean all valves before sending and indicate if they have been used with dangerous liquids. Help us to prevent accidents!



USKON AKIŞKAN KONTROL SİSTEMLERİ SANAYİ VE TİCARET LTD. ŞTİ.

Kemankeş Kara MustafaPaşa Mah. Ağaç Tulumba Sok. No: 4/A Karaköy / İstanbul Tel: +90 (212) 251 05 05 Fax: +90 (212) 251 05 79 info@us-kon.com.tr